

Technical sheet :

# 180 ATJ



 **MANITOU**  
HANDLING YOUR WORLD

Capacities		Metric
Working height	h21	18.19 m
Floor height (access)	h20	0.40 m
Platform height	h7	16.19 m
Max. outreach		10.51 m
Overhang		7.55 m
Pendular arm rotation (bottom)		+59.50 °
Platform capacity	Q	230 kg
Turret rotation		350 °
Platform rotation (right / left)		90 ° / 90 °
Number of people (indoor / outdoor)		2 / 2
Weight and dimensions		
Platform weight*		7430 kg
Platform dimensions (length x width)	lp / ep	1.80 m x 0.80 m
Overall length	l1	7.79 m
Overall width	b1	2.32 m
Overall height	h17	2.47 m
Overall length (stowed)	l9	5.56 m
Overall height (stowed) **	h18	2.56 m
Counterweight offset (turret at 90°)	a7	0.22 m
Counterweight Oversize / Reach		0.22 m
Internal turning radius (over tyres)	b13	1.38 m
External turning radius	Wa3	3.75 m
Ground clearance at centre of wheelbase	m2	0.40 m
Wheelbase	y	2.20 m
Performances		
Drive speed - stowed		5 km/h
Drive speed - raised		1 km/h
Gradeability		45 %
Permissible leveling		5 °
Wheels		
Tires type		Foam-filled
Drive wheels (front / rear)		2 / 2
Steering wheels (front / rear)		2 / 2
Braking wheels (front / rear)		0 / 2
Engine/Battery		
Engine brand / model		Kubota - D1105-E4B
Engine norm		Interim Tier 4, Stage IIIA, Stage V
I.C. Engine power rating / Power		24.80 Hp / 18.50 kW
Miscellaneous		
Ground Pressure		10 dan/cm2
Hydraulic Pressure		340 bar
Hydraulic tank capacity		54 l
Fuel tank		52 l
Vibration on hands/arms		< 0 m/s <sup>2</sup>
Daily consumption **		4.26 l
Standards compliance		
This machine is in compliance with:		European directives: 2006/42/EC- Machinery (revised EN280:2013) - 2004/108/EC (EMC) - 2006/95/EC (Low voltage)

# 180 ATJ - Load chart

Load Chart for MEWP Metric



# 180 ATJ - Dimensional drawing

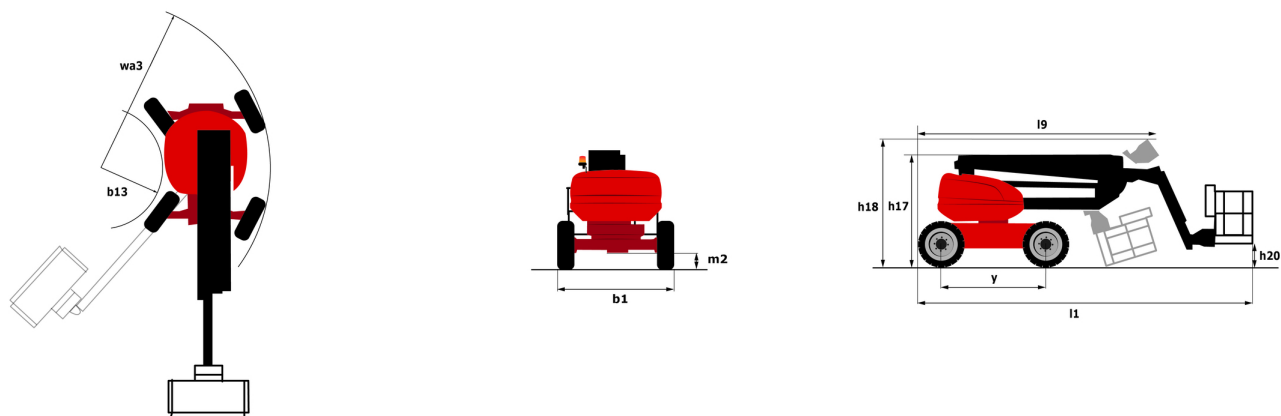

# Equipment

---

## Standard

220V predisposition in the platform  
4 simultaneous movements  
4 wheel drive  
4 wheel steer with crab mode  
Audible alarm and illuminated indicator lamp (leveling, overload, lowering)  
Backup electrical pump  
Basket 1,800 mm  
CAN bus technology  
Differential locking on rear axle  
Easy Manager  
Emergency stop button in platform and on frame  
Fuel gauge with low level indicator  
Fully galvanized basket with demountable floor  
Hour meter  
Leveling unlocking  
Load sensing pump  
Operator presence pedal  
Oscillating front axle  
Rear axle with limited slip differential  
Steer and rotate  
Stop & Go system

## Optional

Battery charger  
Battery cut-off  
Biodegradable oil  
Coded anti-start  
Cold weather protection oil  
Continuous turret rotation  
Exhaust line protection, spark arrester and fume reduction system  
Fully galvanized basket 1800mm / 5'11" with lateral door  
Galvanized basket 2,100 mm  
Highly capacity battery  
Lockable fuel cap  
On-board generator (3,5 or 5 kW)  
Personalized paintwork  
Safety harness  
Secondary Protection System (SPS)  
Spark arrester  
Water heater  
Water predisposition  
Working light



**Head Office**

B.P. 249 - 430 rue de l'Aubinière

44150 Ancenis Cedex - France

Tel: +33 (0)2 40 09 10 11 - Fax: +33 (0)2 40 09 10 97

[www.manitou.com](http://www.manitou.com)



This publication provides a description of the configuration versions and options for Manitou products, which may differ for equipment. The equipment presented in this brochure may be part of a series, as an option, or it may not be available, depending on the versions. Manitou reserves the right, at any time and without notice, to amend the specifications described and represented. The specifications provided do not bind the manufacturer. For more details, please contact your Manitou agent. This is not a contractually binding document. The presentation of the products is not contractually binding. List of specifications non-exhaustive. The logos as well as the visual identity of the company are owned by Manitou and cannot be used without authorisation. All rights reserved. The photos and diagrams contained in this brochure are only provided for consultation and information purposes.

MANITOU BF SA - Limited company with board of directors - Share capital: 39,668,399 euros - 857 802 508 RCS Nantes